

**TOOLS REQUIRED FOR ASSEMBLY:**  
 Cordless Drill W/ #2 Phillips Head Bit  
 T-20 Torque Head Bit

**415NSR INSTALLATION INSTRUCTIONS**

Parts List		
ITEM	QTY	DESCRIPTION
A	1	Track
B	4	#8 x 3/4" Pan Ph Quadrex PBS (Zinc)
C	1	415NSR
D	1	Arm Mechanism
E	1	Plastic Track Stop
F	2	#10x1/2" Round Head Slotted One Way Tamper Resistant (Zinc)
G	6	#8-32x3/8" Ph Ph Ms(Black)
H	6	U-nut
J	2	#8x3/4" T-20 Pan Head Tamper Resistant (Zinc)

GLUE STRIPS WITH GLUE DOTS

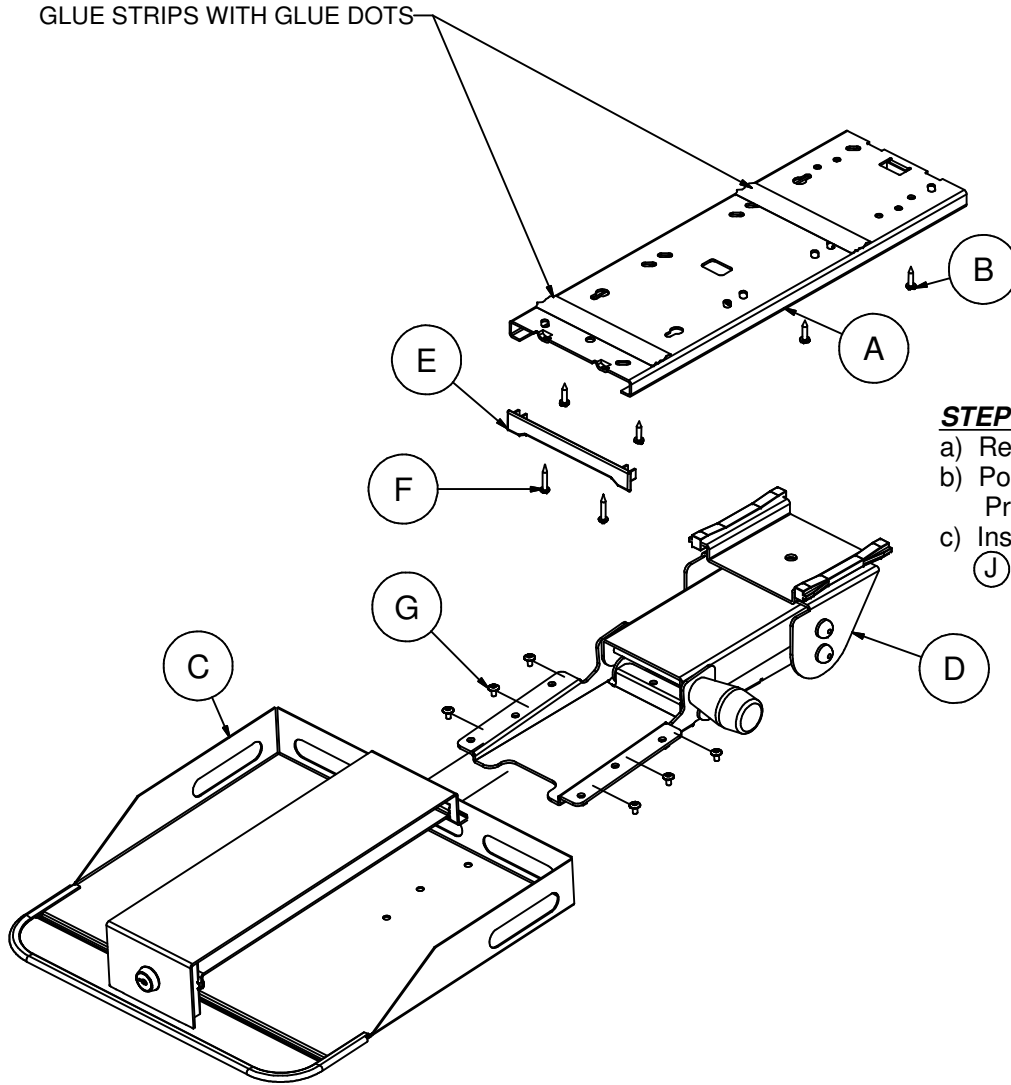

**STEP 1:** Mount (A) Track to bottom of worksurface as follows:

- Remove glue strips from track so glue dots are exposed.
- Position Track to be square and 1" setback from the front edge of the worksurface. Press track firmly into position so glue dots support the Track under the worksurface.
- Install (B) fasteners (four per track). Be sure not to over tighten screws. Also install (J) tamper resistant fasteners (two per track).

