



**TOOLS REQUIRED FOR ASSEMBLY:**  
Cordless Drill W/ #2 Square-Recess Bit  
and T20 Torx Drive Bit Driver

Parts List			
ITEM	QTY	PART NUMBER	DESCRIPTION
A	1	100620041	415 NotebookSafe Drawer
B	4	080420041	#10 X 3/4" Combo Drive Wood Screw
C	4	021020051	#8 X 3/4" T-20 Pan Head Tamper Resistant (Zinc)

**STEP 1:** Install (A) to bottom of worksurface as follows:

- a) Extend drawer slides to there open/locked position and locate front of slide 3 5/8" from the edge of worksurface.
- b) Install and tighten fasteners (B) in location shown below.
- c) Operate the 415NSD to check for slides binding. If slides bind loosen fasteners and readjust until slides freely.
- d) Install the security fasteners (C)

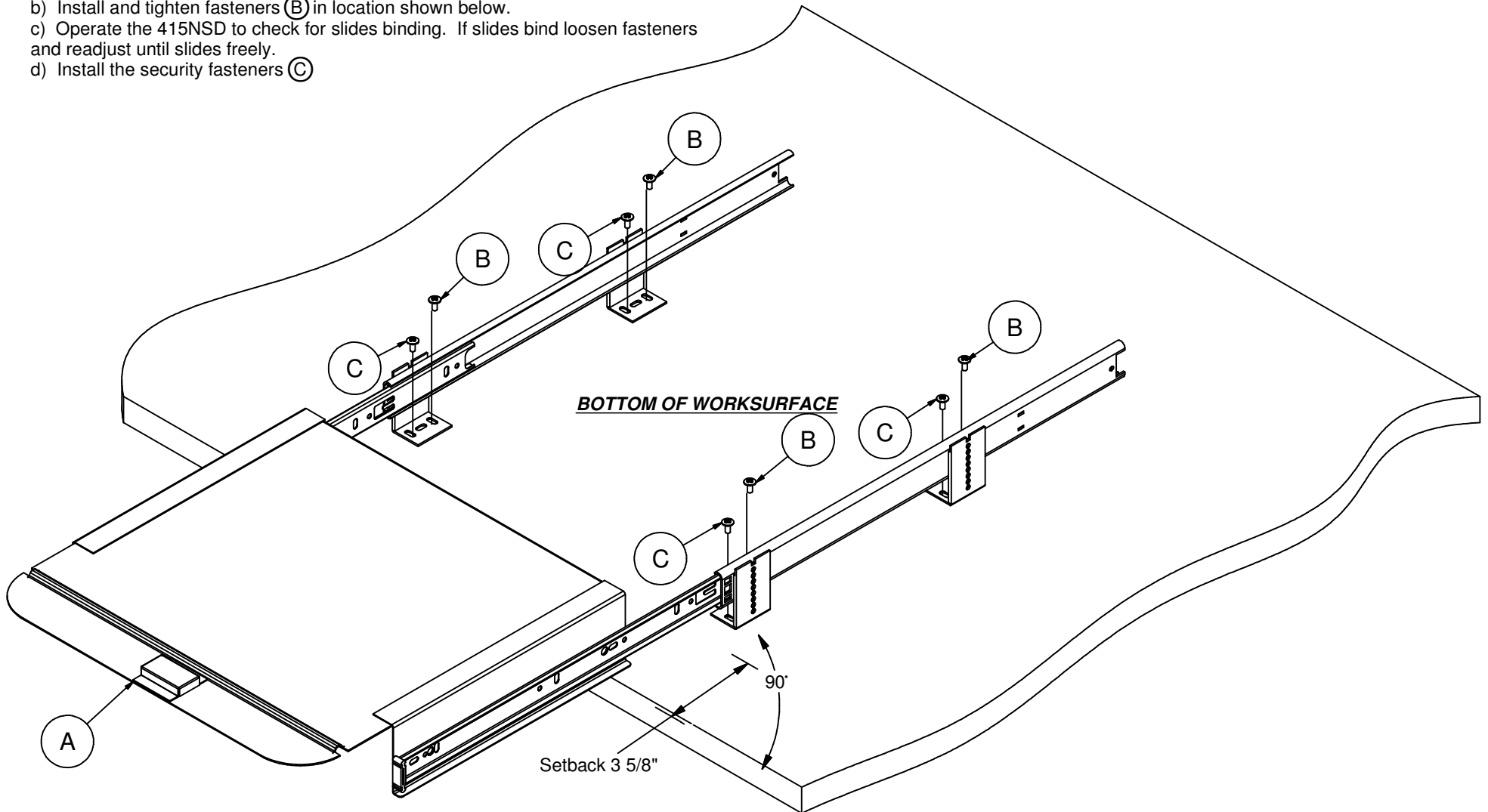

For questions or concerns, please call K & A Manufacturing, Inc. 1-800-298-4351 available Monday-Friday 8:00 AM to 5:00 PM (Central Time)

[www.rightangleproducts.com](http://www.rightangleproducts.com)

5/12/2005