

## 200CPU HOLDER INSTALLATION INSTRUCTIONS

**STEP 2:** Place straps around the CPU and center the (C) CPU holder, tighten straps so bottom of CPU holder is snug with the CPU.

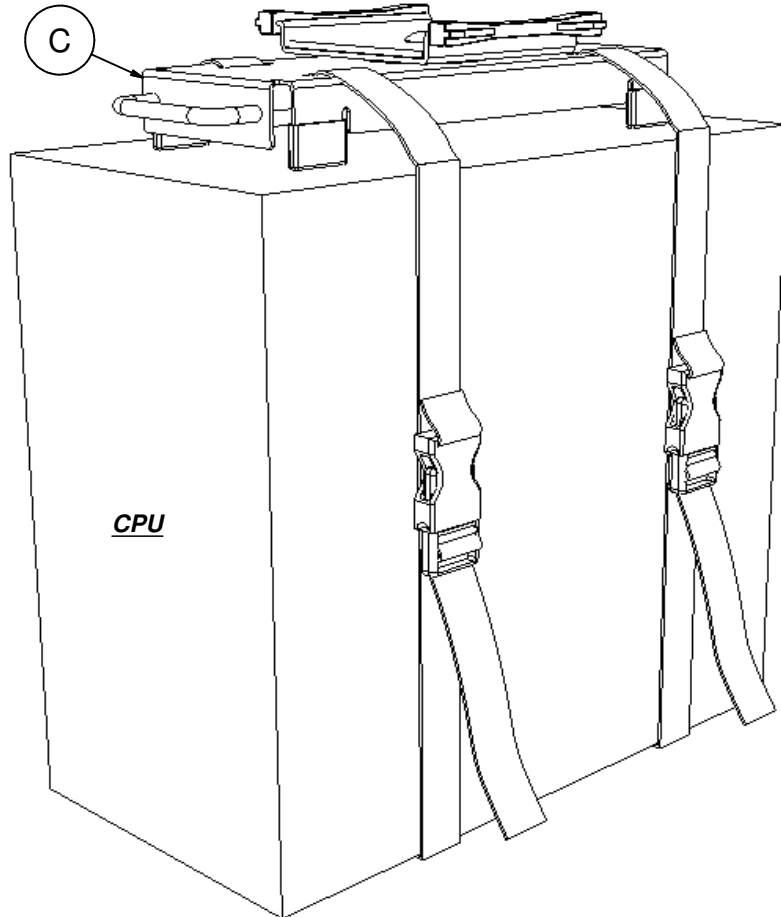

**STEP 3:** Slide CPU Holder with CPU into track. Fasten the (A) Track Stop into place with (G) #8 X 1 1/2" Pan Sq Quadrex PBS screw, going through the (F) Track Stop, Track, and into the bottom of the worksurface. Installation is finished.

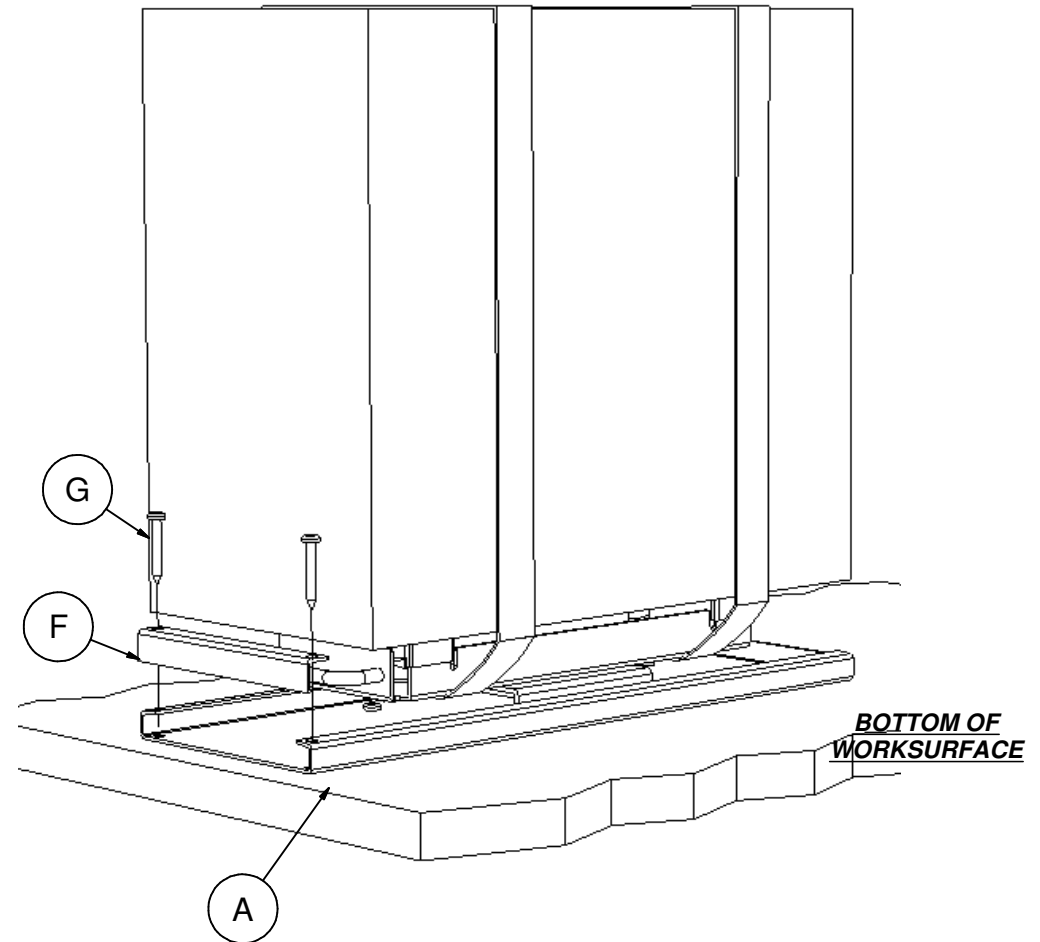

For questions or concerns, please call K & A Manufacturing, Inc. 1-800-298-4351 available Monday-Friday 8:00 AM to 5:00 PM (Central Time)

[www.rightangleproducts.com](http://www.rightangleproducts.com)

01/20/2005