

100VS/S ARTICULATING KEYBOARD INSTALLATION INSTRUCTIONS

STEP 2: Slide (D) Arm Mechanism into the grooves of the (A) Track.

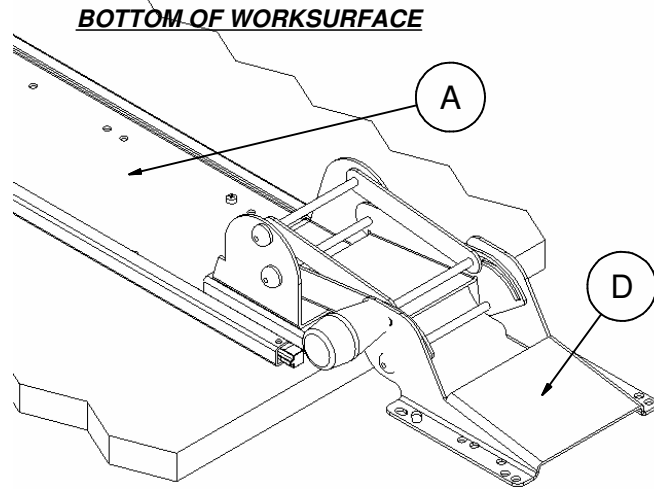

STEP 3: Insert the (E) Track Stop into place with two (F) fasteners, going through the Track and into the Track Stop.

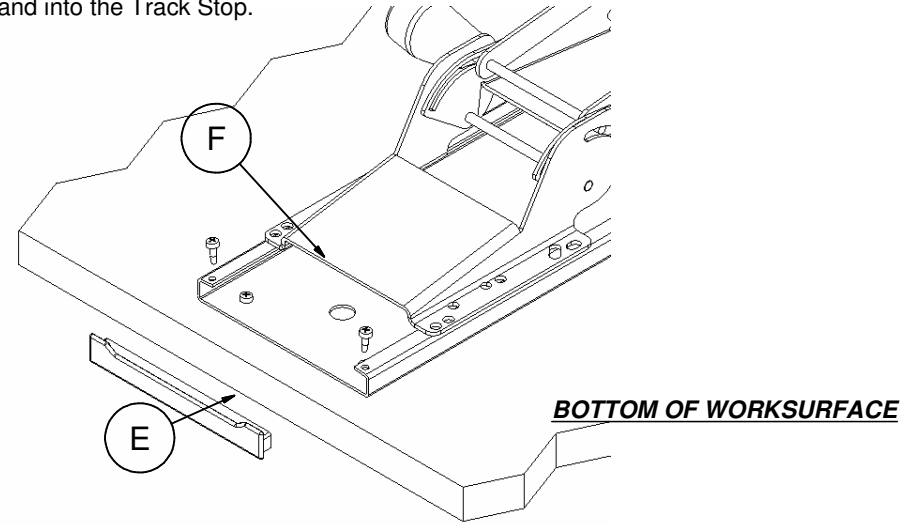

STEP 4: Place (C) Keyboard Tray onto (D) Arm Mechanism and align with holes on arm mechanism then fasten with (G) #8-32 X 3/8" Th Ph Ms (Black/OX) and (H) #8-32 Serr Fl Nut (Zinc) then tighten with Wrench and #2 Phillips Head Bit. (J) Cord "D" Clips (not shown) are used for cord management for the keyboard and mouse cords.

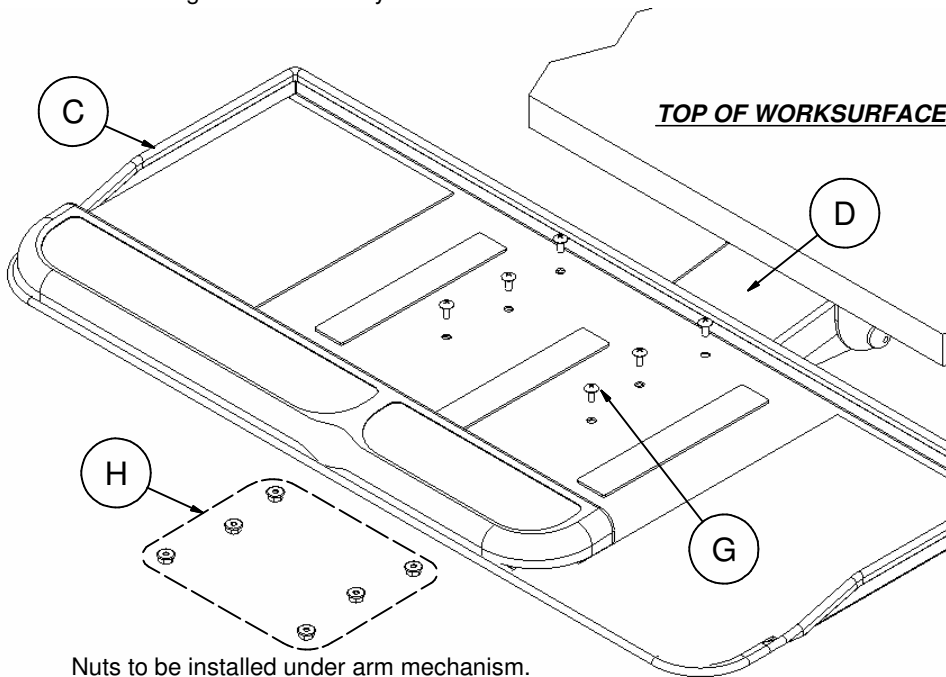

STEP 5: Installation is finished. To operate the system:

- Push in/pull out the Keyboard Tray.
- For height / tilt adjustment loosen knob counter clockwise, adjust keyboard to elbow height and tilt to a neutral or negative position. Tighten knob clockwise.
- The Arm Mechanism will also swivel to the left or right with a moderate push to the side.
- If positive keyboard position is desired remove tilt knob handle, washer and remove positive lockout tab with slotted screw driver.

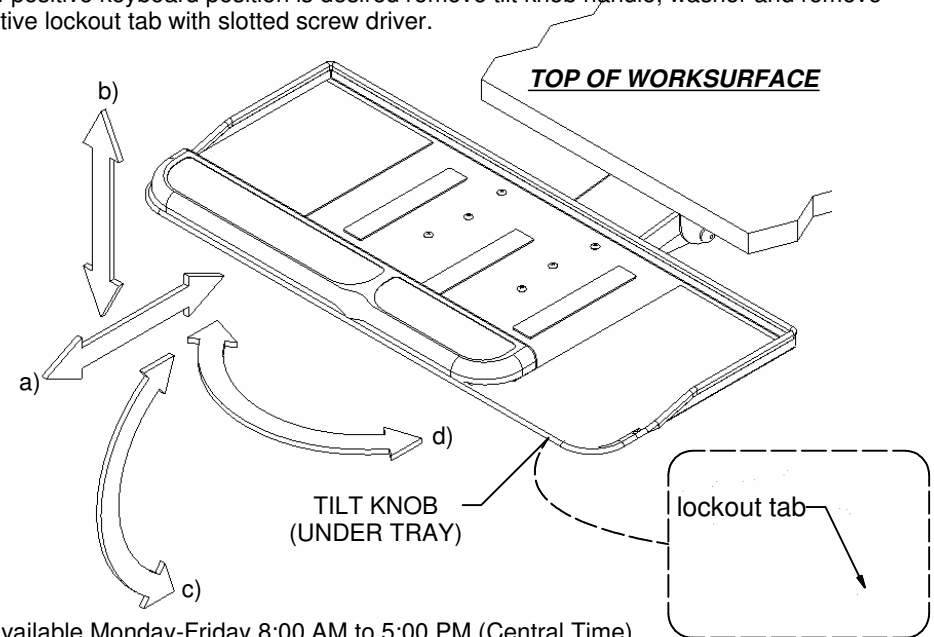

For questions or concerns, please call K & A Manufacturing, Inc. 1-800-298-4351 available Monday-Friday 8:00 AM to 5:00 PM (Central Time)

www.rightangleproducts.com

04/22/2005