

TOOLS REQUIRED FOR ASSEMBLY:
 Cordless Drill W/ #2 Square-Recess Bit &
 #2 Phillips Head Bit
 11/32" or 9mm Wrench

Parts List			
ITEM	QTY	PART NUMBER	DESCRIPTION
A	1	N/A	19" or 23" Track
B	6	080420041	#8 X 3/4" Pan Ph Quadrex PBS (Zinc)
C	1	N/A	Keyboard Tray
D	1	N/A	Arm Mechanism (100F/S,FX/S,FHL/S and 200FSS/S)
E	1	080420043	Track Stop (Metal)
F	2	080520041	#8 X 1 1/2" Pan Ph Quadrex PBS (Black O/X)
G	6	081020041	8-32 X 3/8" Th Ph Ms (Black O/X)
H	6	081020042	8-32 Serr FI Nut (Zinc)
J	2	080520043	Cord "D" Clip (not shown)

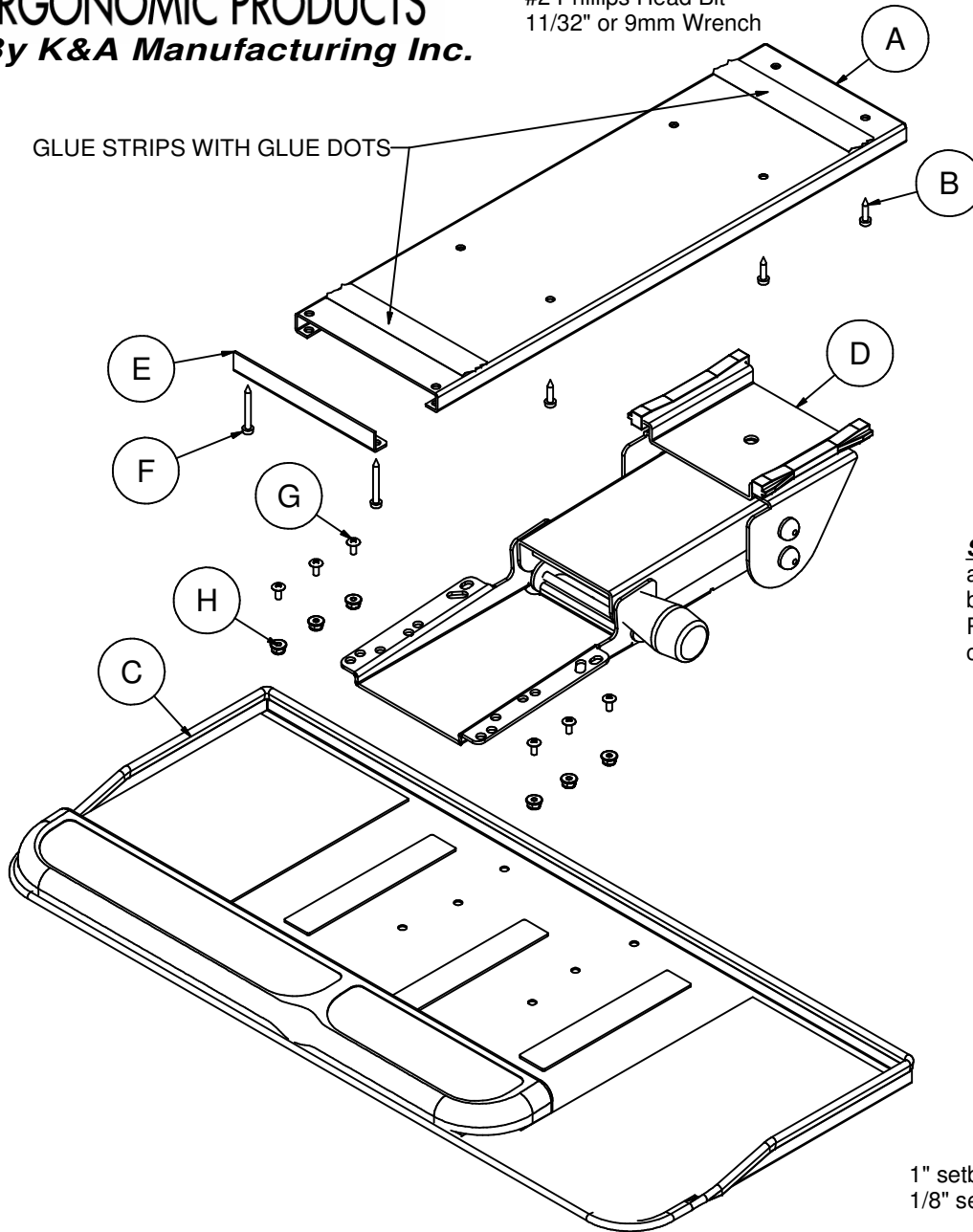

STEP 1: Mount (A) Track to bottom of worksurface as follows:
 a) Remove glue strips from track so glue dots are exposed.
 b) Position Track to be square and 1" or 1/8" setback from the front edge of the worksurface. Press track firmly into position so glue dots support the Track under the worksurface.
 c) Install (B) fasteners (six per track). Be sure not to over tighten screws.

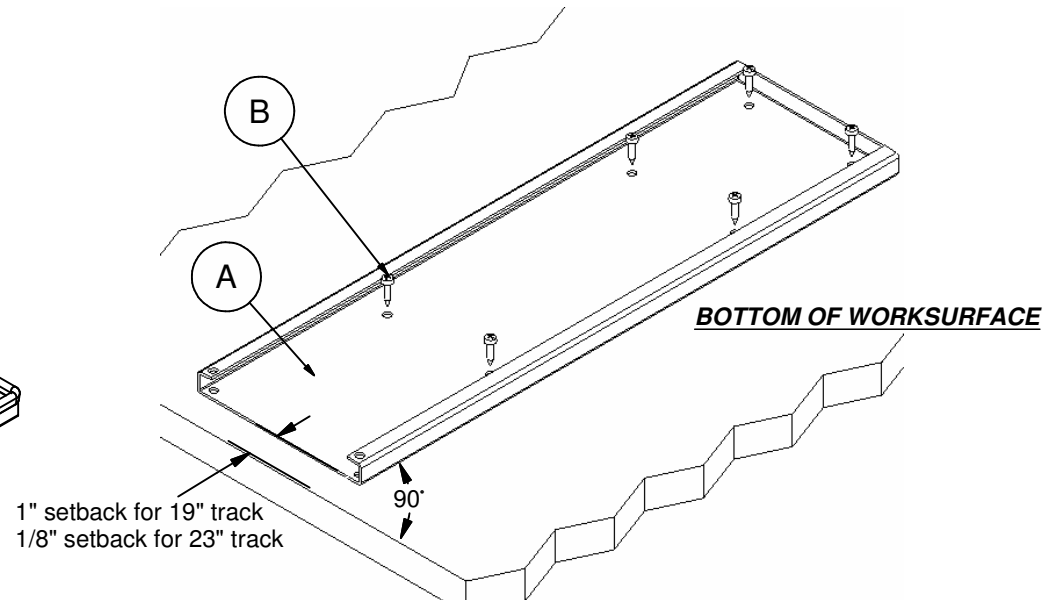

For questions or concerns, please call K & A Manufacturing, Inc. 1-800-298-4351 available Monday-Friday 8:00 AM to 5:00 PM (Central Time)